

Series 6000

KUNKLE

Features

- **O-ring seats available** for exceptional leak-free performance, reduced maintenance cost, multiple cycles with tight shutoff, improved seating integrity.
- **Wide hex on valve nozzle** provides wrenching service clearance for easy installation.
- **Dual control rings offer easy adjustability** for precise opening with minimum preopen or simmer and exact blowdown control.
- **Pivot between disc and spring** corrects misalignment and compensates for spring side thrust.
- **Grooved piston model disc** reduces sliding area and friction.

Model Descriptions

Model 6010: Side outlet. Full nozzle design with bronze/brass trim. Available with O-ring seats. For exceptional leak-free performance.

Model 6021: Same as Model 6010 with Teflon® (PFA) disc insert. For exceptional leak-free performance (use on steam only).

Model 6030: Same as Model 6010 except SS trim (nozzle and disc). Available with O-ring seats for exceptional leak-free performance.

Model 6182: Top outlet. Full nozzle design with bronze/brass trim. O-ring seat available for exceptional leak-free performance.

Model 6121: Same as Model 6182 with Teflon® (PFA) disc insert. For exceptional non-leak performance (use on steam only).

Model 6130: Same as Model 6182 except SS trim (nozzle and disc). O-ring seat available for exceptional leak-free performance.

Model 6186: Top outlet. Full nozzle design with bronze/brass trim. 150 psig [10.3 barg] maximum set pressure. Replaces Model 86 (original equipment only).

Model 6283: Over-sized side outlet. Full nozzle design bronze/brass trim.

Model 6221: Same as Model 6283 with Teflon® (PFA) disc insert. For exceptional leak-free performance (use on steam only).

Model 6230: Same as Model 6283 except SS trim (nozzle and disc).

Model 6933: Same as Model 6010 except certified for ASME code Section IV. Low pressure steam heating boilers set at 15 psig [1.0 barg] only.

Model 6934: Same as Model 6021 except certified for ASME code Section IV. Low pressure steam heating boilers set at 15 psig [1.0 barg] only.

ASME Section I and VIII, Steam, 'V' and 'UV', ASME Section VIII, Air/Gas 'UV' National Board Certified. Models 6933, 6934, and 6935 are ASME Section IV, 'Steam', 'HV' National Board Certified. PED Certified for Non-Hazardous Gas.

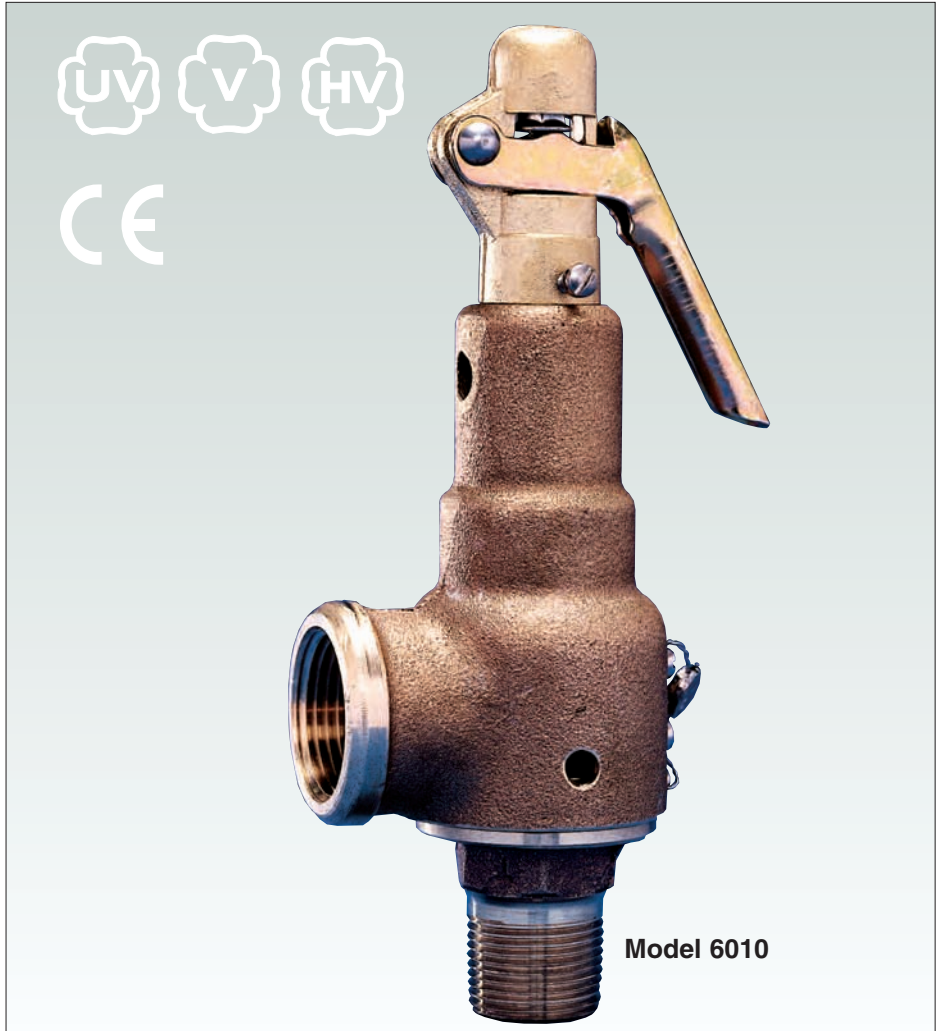

Model 6010

Model 6935: Same as Model 6030 except certified for ASME code Section IV. Low pressure steam heating boilers set at 15 psig [1.0 barg] only.

Applications

- Steam Boilers and Generators.
- Air/Gas Compressors - reciprocating or rotary - portable or stationary, intercoolers and aftercoolers.
- Pressure Vessels - containing steam, air or non-hazardous gas. Including tanks, receivers, sterilizers and autoclaves.
- Pressure Reducing Stations - protection of the discharge or low pressure side of system.

Pressure and Temperature Limits

Models 6010, 6021, 6182, 6283, 6221
Steam Service

3 to 250 psig [0.2 to 17.2 barg]
 -60° to 406°F [-51° to 208°C]

Air/Gas Service

3 to 300 psig [0.2 to 20.7 barg]
 -60° to 406°F [-51° to 208°C]

Models 6030, 6130, 6230

Steam and Air/Gas Service

3 to 300 psig [0.2 to 20.7 barg]
 -60° to 425°F [-51° to 218°C]

Notes

1. Resilient seats determine temperature range (see page 11).
2. Teflon® is a registered trademark of E.I. du Pont de Nemours Company.

tyco / Flow Control

Total Flow Control Solutions™

Kunkle is either a trademark or registered trademark of Tyco International Services AG or its affiliates in the United States and/or other countries. All other brand names, product names, or trademarks belong to their respective holders.

Series 6000

Parts and Materials

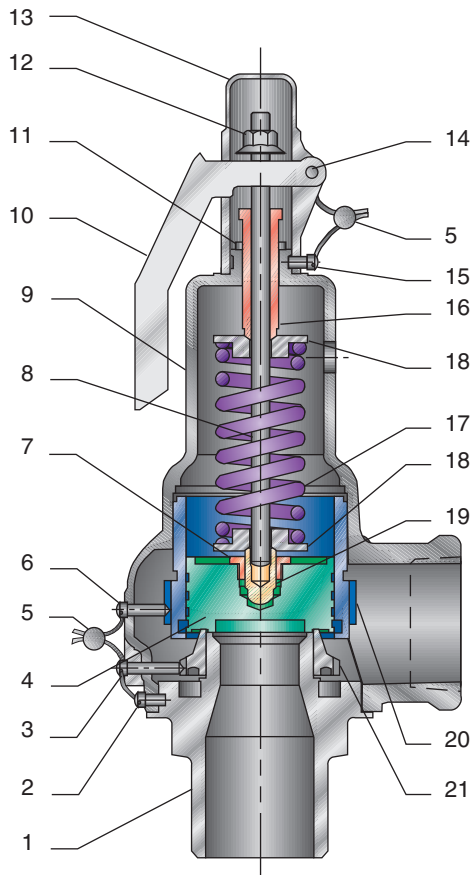

**Models 6010, 6030, 6283,
6230, 6933, 6935**

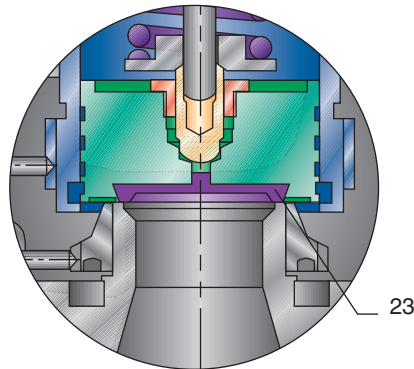

**Models 6121, 6221, 6934
Teflon® Seat Configuration**

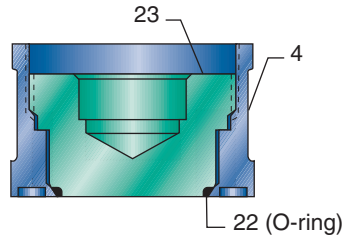

**Models 6010, 6030, 6283,
6230, 6933, 6935
Optional Soft Seat**

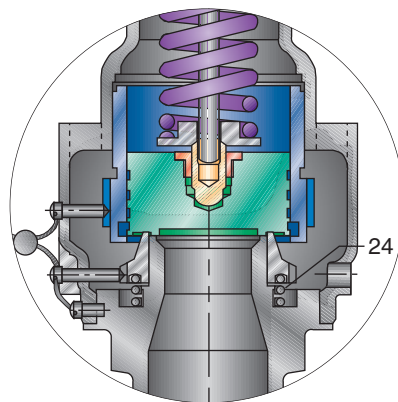

**Models 6182, 6121, 6130, 6186
Top Outlet Configuration**

Series 6000

Parts and Materials

No.	Part Name	Materials
1	Nozzle	BRS B283-C48500 for D Orifice ³ BRZ SB62 for E thru J Orifice ³
2	Body Set Screw	SS 18-8
3	Warn Ring Set Screw	SS 18-8
4	Disc	B21 C48500 ⁴
5	Wire and Seal	SS Wire and Lead Seal
6	Guide Set Screw	SS 18-8
7	Retainer Nut ²	Brass B16
8	Stem	SS, A582 TY416
9	Body	BRZ B584-C84400
10	Lever	STL A109 or JIS SPCC Equivalent/ZN Plated Yellow
11	Jam Nut	Brass B16
12	Lift Nut	STL A108-1018/ZN Plated
13	Cap	BRS B176 Alloy 230A
14	Lever Pin	STL A108-12L14
15	Cap Set Screw	SS 18-8
16	Compression Screw	BRS B16
17	Spring	ASTM A-313 TY 631
18	Spring Step	BRS B16
19	Stem Retainer	BRS B16
20	Guide	BRS B16 for D and E Orifice BRZ B584-C84400 for F thru J Orifice
21	Warn Ring ⁷	BRS B16
22	Seat	<i>Note 1</i>
23	Seat Retainer	BRS B16 ⁵
24	Warn Ring Spring ⁶	STL

Notes

- Models 6021, 6121, 6221 and 6934 Teflon®, optional O-ring seat available for all others except Models 6933 and 6935.
- Section IV only.
- Models 6030, 6130, 6230 and 6935 are SS SA351-CF8.
- Models 6030, 6130, 6230 and 6935 are SS SA479-304 (D thru H Orifice) or SS SA479-316 (J Orifice).
- Models 6030, 6130 and 6230 are SS SA479-304.
- Variation 02 (vibration dampening) only.
- Soft seat 'D' and 'E' orifice require special warn ring (notch on O.D. of fins).

Series 6000

Series 6000 and Models 6933-6935 ASME Section I and VIII, Steam, ASME Section VIII, Air/Gas National Board Certified. Models 6933-6935 are ASME Section IV, 'Steam,' National Board Certified

Specifications

Model Number ¹	Orifice	Connections ANSI Standard		Valve Dimensions in [mm]						Approximate Weight	
		Inlet in [mm]	Outlet in [mm]	A		B		C		lb	[kg]
60**DC#	D	1/2 [12.7]	3/4 [19.0]	2 1/8 [54]	15/8 [41]	6 1/2 [165]	1 1/2 [0.7]				
60**DD# ²	D	3/4 [19.0]	3/4 [19.0]	2 1/8 [54]	15/8 [41]	6 1/2 [165]	1 3/4 [0.8]				
61**DC#	D	1/2 [12.7]	—	—	—	6 1/2 [165]	1 1/4 [0.6]				
60**ED#	E	3/4 [19.0]	1 [25.4]	2 3/8 [60]	1 3/4 [44]	7 1/2 [191]	2 1/2 [1.1]				
60**EE# ²	E	1 [25.4]	1 [25.4]	2 1/2 ⁴ [64]	1 3/4 [44]	7 5/8 ⁵ [194]	2 3/4 [1.2]				
61**ED#	E	3/4 [19.0]	—	—	—	7 1/2 [191]	2 1/4 [1.0]				
62**ED#	E	3/4 [19.0]	1 1/4 [31.75]	2 7/8 [73]	1 3/4 [44]	7 1/2 [191]	2 3/4 [1.2]				
60**FE#	F	1 [25.4]	1 1/4 [31.8]	2 5/8 [67]	2 [51]	8 1/2 [216]	3 1/2 [1.6]				
60**FF# ²	F	1 1/4 [31.8]	1 1/4 [31.8]	2 7/8 [73]	2 [51]	8 3/4 [222]	3 3/4 [1.7]				
61**FE#	F	1 [25.4]	—	—	—	8 1/2 [222]	3 1/4 [1.5]				
62**FE#	F	1 [25.4]	1 1/2 [38.0]	2 7/8 [73]	2 [51]	8 1/2 [222]	3 3/4 [1.7]				
60**GF#	G	1 1/4 [31.8]	1 1/2 [38.0]	3 1/8 [79]	2 3/8 [60]	9 5/8 [244]	5 1/2 [2.5]				
60**GG# ²	G	1 1/2 [38.0]	1 1/2 [38.0]	3 3/8 [86]	2 3/8 [60]	10 [254]	5 3/4 [2.6]				
61**GF#	G	1 1/4 [31.8]	—	—	—	9 5/8 [244]	5 [2.3]				
62**GF#	G	1 1/4 [31.8]	2 [51.0]	3 3/8 [86]	2 1/4 [57]	9 5/8 [244]	5 3/4 [2.6]				
60**HG#	H	1 1/2 [38.0]	2 [51.0]	3 5/8 [92]	2 3/4 [70]	10 5/8 [270]	7 3/4 [3.5]				
60**HH# ²	H	2 [51.0]	2 [51.0]	4 1/8 [105]	2 3/4 [70]	11 1/8 [283]	8 [3.6]				
61**HG#	H	1 1/2 [38.0]	—	—	—	10 5/8 [270]	7 1/4 [3.3]				
62**HG#	H	1 1/2 [38.0]	2 1/2 [64.0]	3 7/8 [98]	3 [76]	10 5/8 [270]	8 [3.6]				
60**JH#	J	2 [51.0]	2 1/2 [64.0]	4 1/4 [108]	3 3/8 [86]	13 5/8 [346]	15 1/2 [7.0]				
60**JJ# ²	J	2 1/2 [64.0]	2 1/2 [64.0]	4 1/2 [114]	3 3/8 [86]	14 [356]	15 3/4 [7.2]				
61**JH#	J	2 [51.0]	—	—	—	13 5/8 [346]	15 [6.8]				
62**JH#	J	2 [51.0]	3 [76.0]	4 5/8 [117]	3 3/8 [86]	13 5/8 [345]	15 1/2 [7.0]				

Dimensions are for reference only.

Notes

1. Replace asterisks with desired model number. Replace # with desired seat material.
2. Model 6030 available only 1/2 x 3/4-inch [12.7 x 19 mm], 3/4 x 1-inch [19 x 25.4 mm], 1 x 1 1/4-inch [25.4 x 31.8 mm], 1 1/4 x 1 1/2-inch [31.8 x 38 mm], 1 1/2 x 2-inch [38 x 51 mm] and 2 x 2 1/2-inch [51 x 64 mm].
3. Models 6933, 6934 and 6935 have same dimensions as Model 6010.
4. 2 1/4" for BSP [57].
5. 7 3/8" for BSP [192.5].

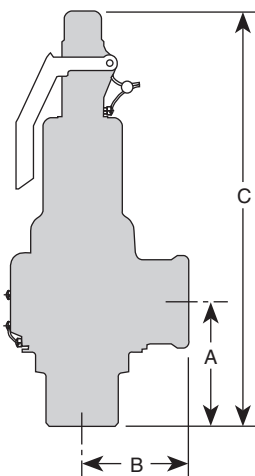

Series 6000

Capacities

Note

1. No code stamp or 'NB' on nameplate below 15 psig set.

Non-code¹ and ASME Section VIII Air (English, SCFM)

Flow Coefficient = 0.878

Set Pressure (psig)	Orifice Area, in ²					
	D (0.121)	E (0.216)	F (0.338)	G (0.554)	H (0.863)	J (1.414)
3	28	50	78	127	198	325
4	32	57	89	146	228	374
6	39	70	109	178	278	456
8	45	80	125	205	319	523
10	50	89	139	228	355	582
15	64	114	178	292	454	744
20	73	131	205	336	524	858
25	83	148	232	381	593	972
30	93	166	259	425	663	1086
35	104	185	289	474	739	1211
40	114	204	319	523	815	1336
45	125	223	349	572	892	1461
50	136	242	379	621	968	1586
55	146	261	409	671	1045	1711
60	157	281	439	720	1121	1837
65	168	300	469	769	1197	1962
70	179	319	499	818	1274	2087
75	189	338	529	867	1350	2212
80	200	357	559	916	1426	2337
85	211	376	589	965	1503	2462
90	221	395	619	1014	1579	2588
95	232	414	648	1063	1656	2713
100	243	434	678	1112	1732	2838
105	254	453	708	1161	1808	2963
110	264	472	738	1210	1885	3088
115	275	491	768	1259	1961	3213
120	286	510	798	1308	2038	3339
125	296	529	828	1357	2114	3464
130	307	548	858	1406	2190	3589
135	318	567	888	1455	2267	3714
140	329	586	918	1504	2343	3839
145	339	606	948	1553	2420	3964
150	350	625	978	1602	2496	4090
160	371	663	1037	1700	2649	4340
170	393	701	1097	1798	2802	4590
180	414	739	1157	1897	2954	4841
190	436	778	1217	1995	3107	5091
200	457	816	1277	2093	3260	5341
210	478	854	1337	2191	3413	5592
220	500	892	1396	2289	3566	5842
230	521	931	1456	2387	3718	6092
240	543	969	1516	2485	3871	6343
250	564	1007	1576	2583	4024	6593
260	586	1045	1636	2681	4177	6843
270	607	1084	1696	2779	4329	7094
280	628	1122	1756	2877	4482	7344
290	650	1160	1815	2975	4635	7594
300	671	1198	1875	3074	4788	7845

Series 6000

Capacities

Non-code¹ and ASME Section VIII Air [Metric, Nm³/h]

Flow Coefficient = 0.878

Set Pressure [barg]	Orifice Area, cm ²					
	D [0.781]	E [1.394]	F [2.180]	G [3.574]	H [5.567]	J [9.123]
0.2	45	81	126	207	322	528
0.3	55	98	154	252	393	644
0.4	63	113	177	290	452	740
0.6	77	138	215	353	549	900
1.0	104	180	281	461	718	1177
1.5	123	220	345	565	880	1443
2.0	146	261	408	669	1042	1708
2.5	171	305	477	782	1218	1996
3.0	196	350	547	896	1396	2288
3.5	221	394	616	1011	1574	2579
4.0	246	439	686	1125	1752	2871
4.5	271	483	756	1239	1930	3163
5.0	296	528	826	1353	2108	3455
5.5	321	572	895	1468	2286	3746
6.0	346	617	965	1582	2464	4038
6.5	371	662	1035	1696	2642	4330
7.0	396	706	1104	1811	2820	4622
7.5	421	751	1174	1925	2998	4913
8.0	446	795	1244	2039	3176	5205
8.5	471	840	1313	2153	3354	5497
9.0	496	884	1383	2268	3532	5788
9.5	521	929	1453	2382	3710	6080
10.0	545	974	1523	2496	3888	6372
10.5	570	1018	1592	2611	4066	6664
11.0	595	1063	1662	2725	4244	6955
11.5	620	1107	1732	2839	4422	7247
12.0	645	1152	1801	2953	4600	7539
12.5	670	1197	1871	3068	4778	7831
13.0	695	1241	1941	3182	4956	8122
13.5	720	1286	2011	3296	5134	8414
14.0	745	1330	2080	3411	5312	8706
14.5	770	1375	2150	3525	5490	8997
15.0	795	1419	2220	3639	5668	9289
16.0	845	1509	2359	3868	6024	9873
17.0	895	1598	2499	4096	6381	10456
18.0	945	1687	2638	4325	6737	11040
19.0	995	1776	2777	4553	7093	11623
20.0	1045	1865	2917	4782	7449	12207

Note

1. No code stamp or 'NB' on nameplate below 1.0 barg set.

Series 6000

Capacities

Note

1. No code stamp or 'NB' on nameplate below 15 psig set.

Non-code¹ and ASME Section VIII Steam (English, lb/h)
Flow Coefficient = 0.878

Set Pressure (psig)	Orifice Area, in ²					
	D (0.121)	E (0.216)	F (0.338)	G (0.554)	H (0.863)	J (1.414)
3	87	155	243	398	621	1017
4	100	178	279	457	711	1166
6	121	215	337	552	860	1409
8	137	245	384	629	980	1606
10	152	271	424	695	1083	1775
15	179	319	500	819	1276	2091
20	206	368	576	944	1471	2410
25	234	417	653	1070	1666	2730
30	261	466	729	1195	1861	3050
35	291	520	813	1333	2076	3401
40	321	573	897	1470	2291	3753
45	351	627	981	1608	2505	4105
50	381	681	1065	1746	2720	4456
55	411	734	1149	1884	2934	4808
60	442	788	1233	2022	3149	5160
65	472	842	1317	2159	3364	5511
70	502	896	1401	2297	3578	5863
75	532	949	1486	2435	3793	6215
80	562	1003	1570	2573	4008	6566
85	592	1057	1654	2710	4222	6918
90	622	1110	1738	2848	4437	7270
95	652	1164	1822	2986	4651	7621
100	682	1218	1906	3124	4866	7973
105	712	1272	1990	3262	5081	8325
110	742	1325	2074	3399	5295	8676
115	773	1379	2158	3537	5510	9028
120	803	1433	2242	3675	5725	9380
125	833	1487	2326	3813	5939	9731
130	863	1540	2410	3950	6154	10083
135	893	1594	2494	4088	6368	10434
140	923	1648	2578	4226	6583	10786
145	953	1701	2662	4364	6798	11138
150	983	1755	2746	4502	7012	11489
160	1043	1863	2915	4777	7442	12193
170	1104	1970	3083	5053	7871	12896
180	1164	2077	3251	5328	8300	13599
190	1224	2185	3419	5604	8729	14303
200	1284	2292	3587	5879	9159	15006
210	1344	2400	3755	6155	9588	15709
220	1404	2507	3923	6430	10017	16413
230	1465	2615	4091	6706	10446	17116
240	1525	2722	4259	6981	10876	17819
250	1585	2829	4428	7257	11305	18523
260	1645	2937	4596	7533	11734	19226
270	1705	3044	4764	7808	12163	19929
280	1766	3152	4932	8084	12592	20632
290	1826	3259	5100	8359	13022	21336
300	1886	3367	5268	8635	13451	22039

Series 6000

Capacities

Non-code¹ and ASME Section VIII Steam [Metric, kg/h]

Flow Coefficient = 0.878

Set Pressure [barg]	Orifice Area, cm ²					
	D [0.781]	E [1.394]	F [2.180]	G [3.574]	H [5.567]	J [9.123]
0.2	39	69	108	177	276	453
0.3	47	84	131	215	335	549
0.4	54	96	150	246	383	628
0.6	65	115	181	296	461	756
1.0	81	144	226	370	576	944
1.5	98	175	273	448	698	1144
2.0	116	207	324	530	826	1354
2.5	135	242	378	620	966	1582
3.0	155	277	433	711	1107	1814
3.5	175	312	489	801	1248	2045
4.0	195	348	544	892	1389	2276
4.5	215	383	599	982	1530	2508
5.0	234	419	654	1073	1671	2739
5.5	254	454	710	1164	1812	2970
6.0	274	489	765	1254	1954	3201
6.5	294	525	820	1345	2095	3433
7.0	314	560	876	1435	2236	3664
7.5	333	595	931	1526	2377	3895
8.0	353	631	986	1617	2518	4127
8.5	373	666	1041	1707	2659	4358
9.0	393	701	1097	1798	2800	4589
9.5	413	737	1152	1888	2942	4820
10.0	432	772	1207	1979	3083	5052
10.5	452	807	1262	2070	3224	5283
11.0	472	843	1318	2160	3365	5514
11.5	492	878	1373	2251	3506	5746
12.0	512	913	1428	2341	3647	5977
12.5	531	949	1483	2432	3788	6208
13.0	551	984	1539	2523	3929	6439
13.5	571	1019	1594	2613	4071	6671
14.0	591	1055	1649	2704	4212	6902
14.5	611	1090	1705	2795	4353	7133
15.0	630	1125	1760	2885	4494	7365
16.0	670	1196	1870	3066	4776	7827
17.0	710	1267	1981	3248	5059	8290
18.0	749	1337	2091	3429	5341	8752
19.0	789	1408	2202	3610	5623	9215
20.0	829	1479	2313	3791	5905	9678

Note

1. No code stamp or 'NB' on nameplate below 1.1 barg set.

Series 6000

Capacities

ASME Section I Steam (English, lb/h)

Flow Coefficient = 0.878

Set Pressure (psig)	Orifice Area, in ²					
	D (0.121)	E (0.216)	F (0.338)	G (0.554)	H (0.863)	J (1.414)
15	173	309	484	793	1236	2025
20	201	358	560	918	1431	2344
25	228	407	637	1044	1626	2664
30	255	456	713	1169	1821	2983
35	283	504	789	1294	2015	3302
40	310	553	866	1419	2210	3622
45	337	602	942	1544	2405	3941
50	365	651	1018	1669	2600	4260
55	392	700	1095	1794	2795	4580
60	419	748	1171	1919	2990	4899
65	447	797	1247	2045	3185	5219
70	474	847	1325	2172	3384	5544
75	503	897	1404	2301	3585	5873
80	531	947	1483	2430	3785	6202
85	559	998	1561	2559	3986	6531
90	587	1048	1640	2688	4187	6860
95	615	1098	1718	2817	4388	7189
100	643	1148	1797	2946	4588	7518
105	671	1199	1876	3074	4789	7847
110	700	1249	1954	3203	4990	8176
115	728	1299	2033	3332	5191	8505
120	756	1349	2112	3461	5392	8834
125	784	1400	2190	3590	5592	9163
130	812	1450	2269	3719	5793	9492
135	840	1500	2348	3848	5994	9821
140	869	1550	2426	3977	6195	10150
145	897	1601	2505	4105	6395	10479
150	925	1651	2583	4234	6596	10808
160	981	1751	2741	4492	6998	11466
170	1037	1852	2898	4750	7399	12123
180	1094	1952	3055	5008	7801	12781
190	1150	2053	3212	5265	8202	13439
200	1206	2153	3370	5523	8604	14097
210	1263	2254	3527	5781	9005	14755
220	1319	2354	3684	6039	9407	15413
230	1375	2455	3842	6297	9808	16071
240	1432	2555	3999	6554	10210	16729
250	1488	2656	4156	6812	10612	17387
260	1544	2756	4313	7070	11013	18045
270	1600	2857	4471	7328	11415	18703
280	1657	2957	4628	7585	11816	19360
290	1713	3058	4785	7843	12218	20018
300	1769	3158	4942	8101	12619	20676

Series 6000

Capacities

ASME Section I Steam [Metric, kg/h]

Flow Coefficient = 0.878

Set Pressure [barg]	Orifice Area, cm ²					
	D [0.781]	E [1.394]	F [2.180]	G [3.574]	H [5.567]	J [9.123]
1.5	95	170	266	436	680	1114
2.0	113	202	316	519	808	1324
2.5	131	234	367	601	936	1534
3.0	149	266	417	683	1064	1744
3.5	167	299	467	765	1192	1954
4.0	185	331	517	848	1320	2164
4.5	203	363	567	930	1449	2374
5.0	222	396	619	1014	1580	2589
5.5	240	429	670	1099	1712	2806
6.0	259	462	722	1184	1844	3022
6.5	277	495	774	1269	1976	3238
7.0	296	528	826	1353	2108	3455
7.5	314	561	877	1438	2240	3671
8.0	333	594	929	1523	2372	3887
8.5	351	627	981	1608	2504	4104
9.0	370	660	1032	1692	2636	4320
9.5	388	693	1084	1777	2768	4537
10.0	407	726	1136	1862	2900	4753
10.5	425	759	1187	1947	3032	4969
11.0	444	792	1239	2031	3164	5186
11.5	462	825	1291	2116	3296	5402
12.0	481	858	1343	2201	3428	5618
12.5	499	892	1394	2286	3560	5835
13.0	518	925	1446	2371	3692	6051
13.5	537	958	1498	2455	3824	6267
14.0	555	991	1549	2540	3957	6484
14.5	574	1024	1601	2625	4089	6700
15.0	592	1057	1653	2710	4221	6917
15.5	611	1090	1704	2794	4353	7133
17.0	629	1123	1756	2879	4485	7349
17.0	666	1189	1860	3049	4749	7782
18.0	703	1255	1963	3218	5013	8215
19.0	740	1321	2066	3388	5277	8647
20.0	777	1387	2170	3557	5541	9080

Models 6933-6935 ASME Section IV, Low Pressure Steam, 'HV' National Board Certified

Steam Relieving Capacities - Models 6933, 6934 and 6935

Steam Capacity, lb/h [kg/h]

Set Pressure (psig) [barg]	Orifice, Area in ² [cm ²]					
	D 0.121 [0.781]	E 0.216 [1.394]	F 0.338 [2.180]	G 0.554 [3.574]	H 0.863 [5.567]	J 1.414 [9.123]
15 [1.0]	190 [86]	338 [153]	530 [240]	868 [394]	1352 [613]	2215 [1005]

Series 6000

Specifications

Service Recommendations for Resilient Seat/Seal Materials

Seat/Seal Materials	Service Recommendation
Viton® A (-10 to 406°F) [-23 to 208°C]	Air and Gas
Ethylene Propylene (-70 to 400°F) [-57 to 205°C]	Steam
Teflon®	Steam

ASME Section I and VIII, Steam, ASME Section VIII, Air/Gas National Board Certified. Models 6930, 6933, 6935 ASME Section IV, National Board Certified

Model Number/Order Guide

Model Number Position	1	2	3	4	5	6	7	7	8	9	10	11	12	13	14	15
Example	6	0	1	0	H	G	M	0	1	—	A	M	0	1	5	0

Model

6010	6130	6230
6021	6186	6933
6030	6283	6934
6182	6221	6935
6121		

Orifice

D	G
E	H
F	J

Inlet Size

C - 1/2-inch [12.7]	G - 1 1/2-inch [38.1]
D - 3/4-inch [19.0]	H - 2-inch [50.8]
E - 1-inch [25.4]	J - 2 1/2-inch [63.5]
F - 1 1/4-inch [31.8]	

Seat Material

- M - Metal
- E - EPR
- V - Viton®

Variation (01 through 99)

- 01 - Plain lever
- 02 - Plain lever with vibration dampener
- 03 - Plain lever with gag
- 60 - BSP Threads

Design Revision

Indicates non-interchangeable revision. Dash (-) if original design.

Valve Service

- A - Steam ASME Section I
- K - Air/Gas ASME Section VIII
- L - Steam ASME Section VIII
- G - Steam ASME Section IV (Models 6933, 6934, 6935 only)
- P - Steam, Non-code
- N - Air, Non-code

Spring Material

- M - SS

Set Pressure

0015 - 15 psig [1.0 barg] only for Models 6933, 6934, 6935

Series 6000

Facility Phone: 828-669-3700
www.kunklevalve.com